

The 12 Volt Pup: A DC Generator You Can Build

Grab a lawn-mower engine and an alternator to build a great 50 A power supply for Field Day or . . .

By Yaniko Palis, VE2NYP

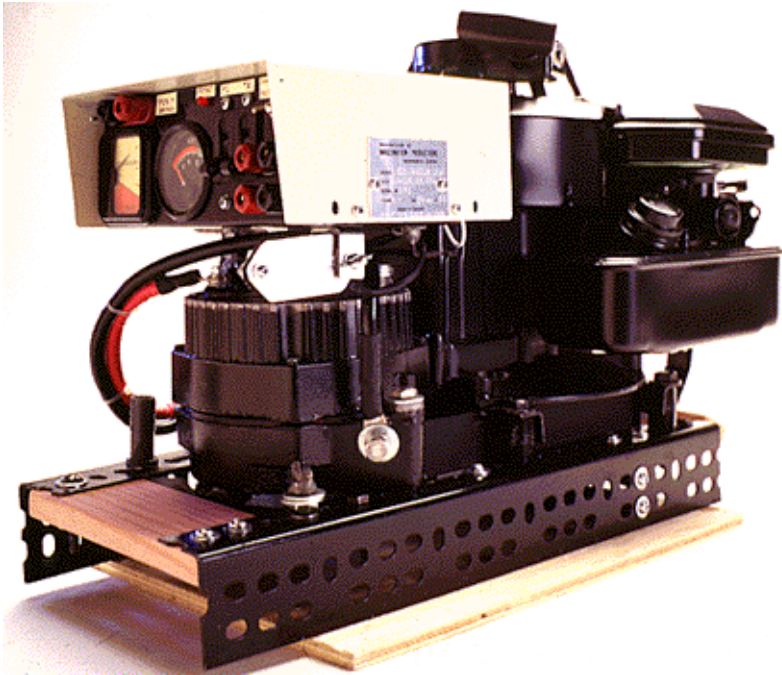

The 12 Volt Pup on its plywood platform and ready to go. Does it look a little like Number Five from the movie, Short Circuit? Photo courtesy of James St. Laurent.

Field Day weekend is the best event of the year! I have always loved wilderness camping and almost any other adventure in the wide-open spaces. Coincidentally, my work often involves setting up all kinds of gear at remote locations for short periods of time—sort of a large-scale version of Field Day. Because of these two interests, Field Day has been my favorite event ever since I became a ham, six years ago. Now, thanks to what I have named “The 12 Volt Pup,” I can easily generate enough power to operate a 100 W transceiver and plenty of accessories at almost any location I choose.

Generating power at remote locations is burdensome, in both equipment weight and cost. The Pup weighs about 45 pounds without a battery; so one person can handle it fairly easily. All told, expect to tote anywhere between 70 and 100 pounds, including batteries, fuel, oil and cables. If needed, you can easily disassemble the Pup into assemblies weighing less than 20 pounds each for backpacking.

The 12 V Pup combines a standard 3.5 horsepower lawn mower engine with an automotive alternator. These two components mount face downward onto two parallel, heavy duty, L-shaped steel rails, as shown in **Figure 1**. Spacers between the components and the rails precisely locate the pulleys and belt within the two steel rails. (See **Figure 2**.) Thus, the unit can rest on any appropriate flat surface. The engine takes a pulley for standard V belts, which makes it compatible with the alternator. Add a car battery and presto! You're in business. This design is amazingly simple.

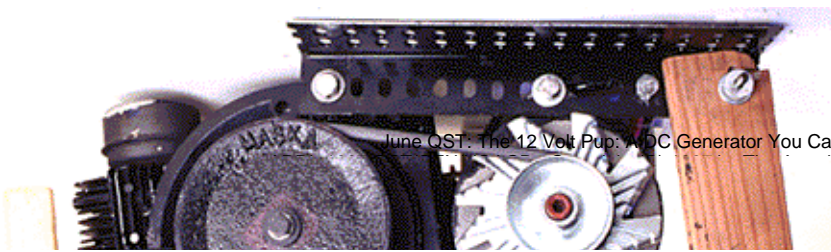

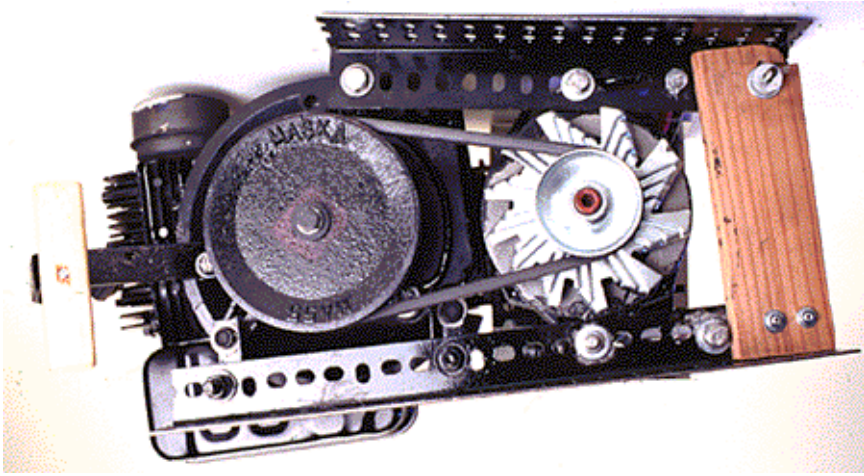

Figure 1—A bottom view without protective shields indicates the simplicity of the basic design. An engine bracket is visible at the left end of the lower (front) rail. The slot to mount the alternator (small pulley with fan) is in the upper (rear) rail. The Pup has wooden handles at each end for carrying. Photo courtesy of James St. Laurent.

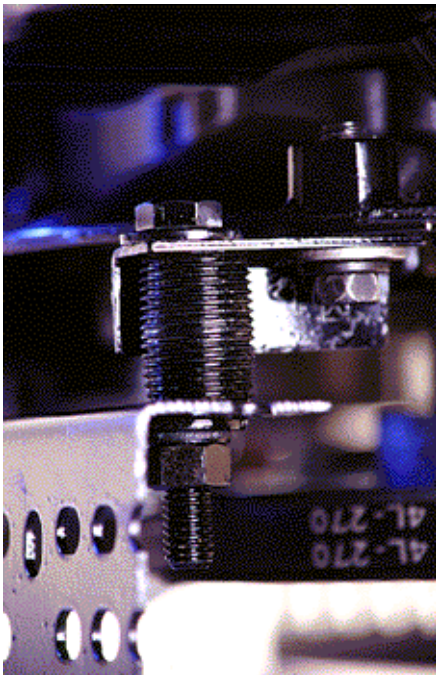

Figure 2—One of the two small engine brackets is above the pipe-coupling spacer. The engine is at the upper right, the front rail at lower left. See Figure 4 for mechanical details. Photo courtesy of James St. Laurent.

An emergency version of this device could be jury rigged in an hour and a half. All you really need is a pulley for the engine, the right size belt and two angle iron rails fitted with simple little mounts. Of course, you must also be willing to critically amputate your car and lawn mower! I decided to build a dedicated unit instead; it sports a control box and it cost me only \$250 for all new parts. If you can scrounge up used parts, \$125 should get you all the basic ingredients. My Pup took about four days to create.

It's great to use the Pup with two or more deep-discharge lead-acid batteries. You can operate with power from one battery while charging the other. Because the Pup will probably charge a battery much faster than you would normally consume the stored energy, the generator may be switched off perhaps half of the time. This conserves fuel and reduces noise pollution.

You could also connect a load directly to the generator—as long as there's a battery connected across the load to stabilize the alternator's output. The engine's little governor works just fine, readily adapting the throttle to changing load conditions. While idling,

J5, J6—50 A terminals or connectors (builder's choice, look at your car's alternator connectors for ideas)

To filter the alternator's output, I installed a 7700 μF electrolytic capacitor across it. The capacitor absorbs the output spikes, leaving a rounded reverse-ramp wave as ripple at 0.40 V (a barely tolerable 3.5%). A 6-W panel lamp acts as a minimum load that protects the battery against overcharging. D1 is a high-current blocking diode. It prevents battery discharge through the lamp and reduces the voltage at the battery to about 13.8 V. I also built a very simple protection circuit that stops the engine should the output exceed 15.5 V (16.0 V peak ac).

During its brief life as a prototype, I have already received many good suggestions on how to improve my control box. For instance, one could stay on an automotive theme and use a ballast resistor, solenoid and an ignition relay to disconnect the battery. You could use a heavy-duty headlight switch with an internal circuit breaker for the power switch. [2] All this is to say, the control-box circuit that I show here is only one of many possibilities—you're welcome to improvise!

Finally, I recommend that you study the unit's output with an oscilloscope to be certain that your valuable equipment won't be damaged if the battery is disconnected while you are running the Pup. Also, some 12 V-only devices might be damaged by the 13.8 V dc that this device normally generates. [Most equipment built for automotive use is rated to +15 V.—Ed.]

Potential Hazards

There are mechanical dangers from the belt, pulleys and other moving parts. It is *your* responsibility to install adequate mechanical shields to prevent bodily harm. The photos show some metal shields and a plywood base that enclose the moving parts. Cut and fit similar shields to your Pup when the main construction is done. Keep fingers, hair, clothes, etc, completely away from all moving parts.

As with all combustion-powered generators, stray sparks may ignite the fuel. Stop the engine to refuel, and don't start it again until any spills have evaporated. Keep all cables, connectors, switches and relay contacts away from the fuel tank, and use this device only in well-ventilated areas. Closely follow *all* of the engine manufacturer's warnings.

Construction

The exact configuration of your Pup will depend on the actual engine and alternator pair that you acquire. That selection will determine the control-box size limitations. (I temporarily assembled the major parts several times to determine the final arrangement.) These notes may ease your construction. A socket set, wrenches and nut drivers turn this process into a breeze. So tune in your favorite listening frequency and enjoy the pleasures of being an insatiable tinkerer.

As you build, take measures against hazards. Prevent access to moving parts; tighten and seal connections against vibration; allow engine and alternator heat to escape; provide ventilation for cables and contacts carrying high currents; plan for exposure to the weather. Use plenty of grommets, wire ties, heat-shrink tubing, hot glue and strain reliefs to render all the connections Murphy proof.

Soldered connections may melt at the current levels found in this project. I crimped—and then soldered—heavy-duty lugs onto all the cable ends. For high-current connections, I bolted the lugs to the various components and jacks. Almost any circuit that shorts in the control box will likely melt. Finally, keep in mind that your Pup will probably operate in wet environments, so paint and seal its controls and connections against rain (and fuel vapors!).

Mechanical Assembly Be an Iron Worker in your own Home

In the following assembly notes, I call the side of my engine with the fuel tank and carburetor on it the "front." The spark plug therefore sticks out of the right side and the crankcase is on the left. The alternator is to the left of the engine, beside the crankcase. This places the alternator on the cooler side of the engine (away from the cylinder). The control box is mounted atop the alternator.

Most lawn-mower engines seem to have the same three reinforced mounting holes on their base. (See **Figure 4.**) Two of the three holes line up with the front, so the long rail goes there. The third hole is at the "rear" and the shorter rail bolts to it. The engine mounts—via two angle-iron brackets, bolts and spacers—to the narrow flange of each main rail; the wide flanges become the vertical sides of the Pup's base. (Refer to **Figure 2.**)

3.5 HP, Vertical-Shaft Lawn-Mower Engine (Such as Briggs and Stratton No. 95900)



June QST: The 12 Volt Pup A DC Generator You Can Build - Page 4

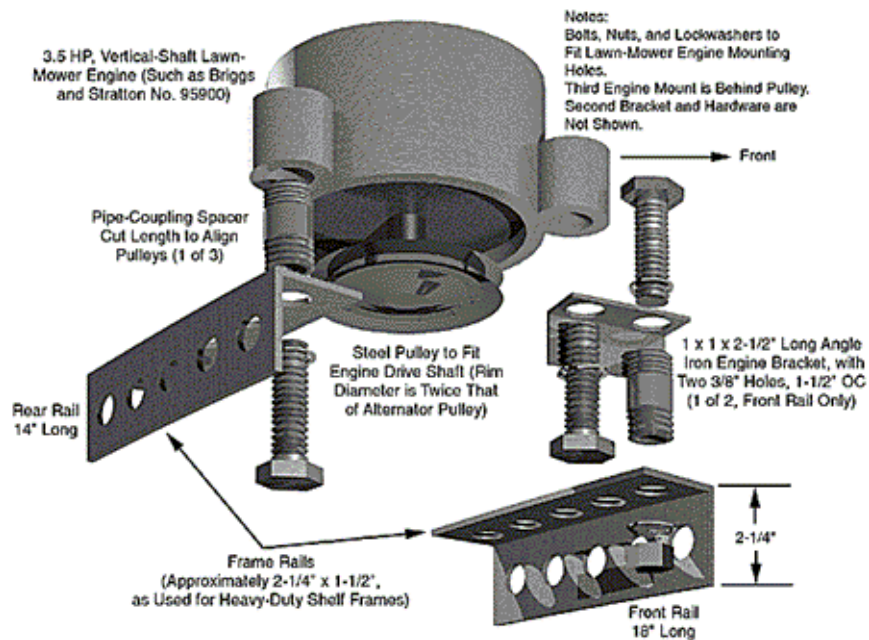

Figure 4—A pictorial of the engine mounting details.

Before you attach the rails, assemble the two engine brackets to the two front mounting holes on the engine. Position them to point away from the engine, toward the front. These brackets create plenty of elbow room for the engine’s new pulley and permit easy access to the oil drain plug. They can swivel slightly, to easily mate with existing holes on the front rail.

Temporarily install the small mounting brackets to the engine, and measure the spacer length (Figures 2 and 4) required to perfectly align the two pulleys. Attach the two main rails so that they extend toward the left as far as possible. It is advantageous that the back rail has only one engine mount because the rail can pivot to accommodate alternators of any diameter.

My alternator did not require spacers because its two mounting holes are flush with the pulley side of its casting. The alternator’s cooling fan blades scraped the edge of the rails so I trimmed the blade corners slightly. The threaded mounting hole of the alternator sits on the back rail and mounts to a slot you will cut out of the back rail later. The plain hole on the alternator casting pivots on the front rail, where it’s attached. Check all clearances, and ensure once more that the two pulleys are in *perfect* alignment. Verify that the rails and spacers support the pulleys above the ground.

Now measure the arc that the alternator must swing along the back rail to accept a standard-length belt. A slot about 2 inches long allows for a 1½-inch variation for belt size, eg, to accept *either* 28 *or* 29-inch belts. (I finished the unit before buying a belt—keep Murphy at bay, I say.) You can plan for standard-length belts during construction using the following formula

$$BL \approx 1.57(D+d) + \sqrt{(D+d)^2 + 4C^2} \tag{Eq 1}$$

where

BL = Belt length (make all measurements in inches)

D = Diameter of large pulley

d = Diameter of small pulley

c = Distance between pulley centers

To use all available space, I installed the control box on simple rubber-damped mounts that I improvised. They poise the box about 1½ inches above the alternator. This allows for air flow and protects the alternator from the rain. Once you have measured all the large internal components and cabling and have established the placement of the control box, pick a suitable cabinet and mark it for machining.

To finish, I picked a spot for a heavy-duty ground lug on the front rail. Thereafter, a few inches will remain open at the left end of the two rails. You can secure a small piece of wood to them, to grasp when lifting the Pup by its left side.

Time to bend, bang, drill, flatten (bang some more), file and sand everything into its final shape. Polish all mechanical grounding points including the engine mounts. Cut the slot out of the back rail with a jigsaw. File off all sharp edges. When the relentless din of power tools, files, twisted blades and flying metal bits finally subsides, you will emerge victorious—and ready for subassembly and painting. Spray paint the mounts, rails and the control box with high-temperature engine enamel.

The protection circuit is built on a piece of perf board. When the output voltage exceeds 15.5 V, a heavy-duty, 5 V PC-board relay grounds the engine's magneto neutralizing wire to stop the engine.

The correct value for R2 depends on the relay's characteristics, so it must be set for each particular relay. To do so, install 10 k Ω pots in place of R1 and R2. Set both pots for maximum resistance. Connect an 18 V variable-voltage power supply across the circuit. (Connect the positive lead to D2's cathode and the negative lead to Q1's emitter.) Set the supply to your desired trigger voltage, and switch on the power. Adjust the R1 pot until the LED just lights. Then adjust the R2 pot until the relay just closes. The two adjustments may interact. Make a final adjustment of R1 when the Pup is complete with the control box installed and the battery disconnected. Finally, remove the pots, measure their values and replace them with combinations of fixed resistors.

Once my basic unit was tested, I added a pair of modified L brackets with a wood handle to the engine's right side. Together they span over the spark plug to protect it from being broken. (Do *not* loosen the cylinder head bolts to mount this!)

The protective mechanical shields that work well on my particular version are four custom-shaped pieces (cut from 22-gauge sheet metal stock, 7x24 inches). Machine screws hold them to the rails. (See Figures 5 and 6.) Attach the entire unit to a solid base (I used plywood) that blocks any access to the underside of the Pup. Editor Robert Schetgen, KU7G, suggests a lightweight hand cart as a base. Again, keep *all* the moving parts *completely* shielded!

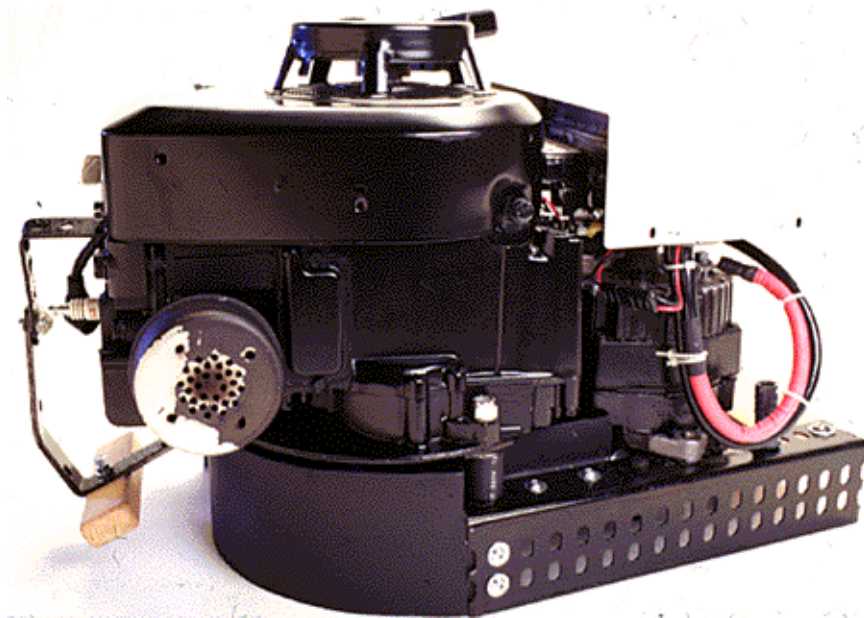
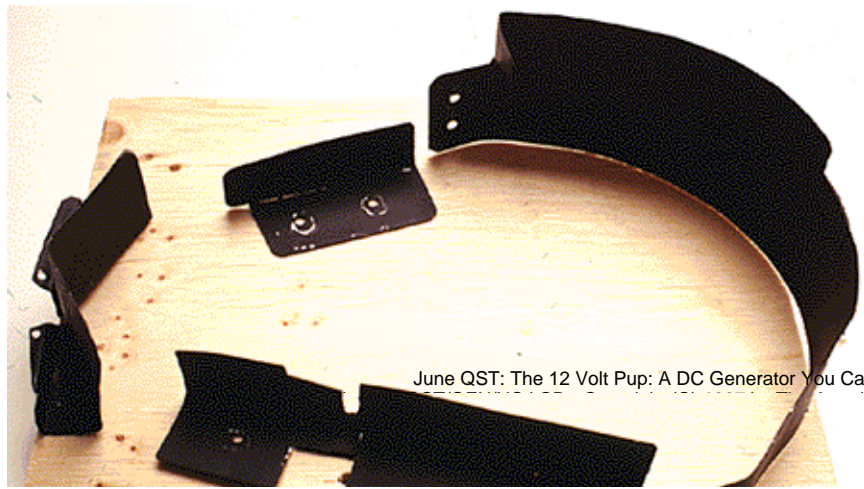

Figure 5—A rear view clearly shows the largest mechanical shield in place and the carry handle—made from L brackets—that protects the spark plug from damage. Photo courtesy of James St. Laurent.



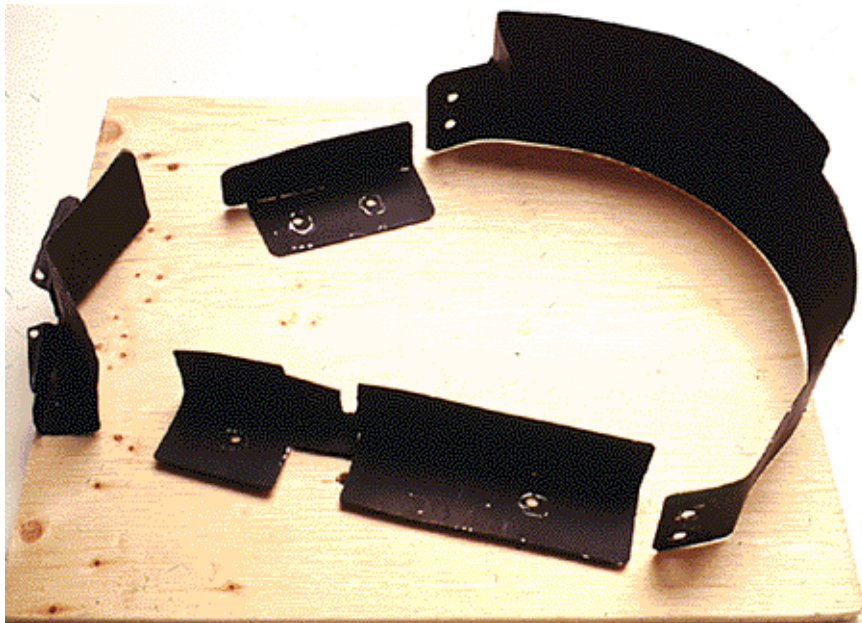

Figure 6—The protective shields, arranged on the plywood base to approximate their mounting positions. Photo courtesy of James St. Laurent.

You will love the 12 Volt Pup! It charges big batteries in a couple of hours. A gallon of gas lasts about four hours with a constant 20 A output. It usually loafs at low speed once a large battery has taken its initial charge. The gang at the Concordia University, VE2CUA, Field Day site was very interested in the Pup, and they first suggested that I write this article. Many members already have their own models churning in their minds. Richard Allix, VE2ARW, promises a miniature pup, to be born from a weed whacker and a motorcycle alternator. You are certainly welcome to write me with your comments and experiences. Good Health, Good Luck and Great DX from VE2NYP!

Notes

¹I did not locate a suitable automatic-reset circuit breaker. Manual-reset breakers in that current range (eg, Potter & Brumfield W31X2M1G-50) cost about \$20, or more. A large fuse would be less expensive. Automobile manufacturers use a fusible link to protect the alternator output.—*Ed.*

²According to E. P. Rolek, K9SQG's "A Source for High-Current Relays," in **Hints and Kinks** (p 73) Wal-Mart may be a good source for such parts.

Yaniko "Nick" Palis first became interested in radio communications in his early teens. After some 20 years of SWLing, he finally decided to get on the air by becoming VE2NYP in 1990. Nick ran his college's broadcast radio station and designed many high-power laser light shows in their heyday (up to the early 1980s). He was a lighting director for films and television specials and would sometimes design custom electronic special effects for movies. He was a unit and location manager for many years. Yaniko is presently a supervising producer for feature films and television series in international distribution. Amateur Radio has revived all those previous technical interests and put them to good use again! You can reach Nick by mail at PO Box 61 station Place du Parc, Montreal, PQ H2W 2M9, Canada.

Partial Parts List for the 12 V Pup:

Motor (1)—(See **Figure 4.**) After searching for a used engine, I bought a new, no frills lawn mower (for \$99) and kept the engine. Recent models have a safety lever connected to a KILL switch on the engine that grounds a *neutralizing wire* to stop the engine. This neutralizing wire connects to the control box ignition switch and protection circuit.

Alternator (1)—(See **Figure 3.**) The one I used is modified as suggested by the folks at a large alternator-remanufacturing company. They rewound a standard alternator with fewer turns so that its internal regulator activates more often (50 A output). A modified unit should cost \$65 to \$85. Any standard internally regulated alternator with an internal charge controller should be fine,

especially for charging automotive batteries. (A used alternator is worth \$15 to \$30.)

Motor Pulley (1)—Get one sized for standard V belts. Its rim diameter should be twice that of the alternator's pulley. This makes the alternator turn twice as fast as the engine. I used a 5¹/₂-inch-diameter pulley. It's a big blessing that the engine shaft's dimensions are standard in every way. A common steel pulley fits right onto the engine's 7/8-inch shaft and accepts a standard locking key (3/16 inch wide by 1/8 inch deep).

V *Belt* to fit the pulleys, likely to be somewhere between 27 and 30 inches long; see text.

Storage Battery (1)—12 V lead-acid battery, 15 Ah or greater. Automotive or motorcycle batteries work, but a deep-discharge battery that tolerates fast charging is best. (Gel cells require a closely controlled charging regimen.) [*]

Steel rails (2) of L-shaped angle iron. This material is commonly used to support heavy-duty, industrial-grade storage shelves. It is perforated with rows of holes that ease assembly, provide ventilation and reduce its weight. The flanges should be at least 2¹/₄×1¹/₂ inches. The front rail is 18 inches long; the back rail is 14 inches long.

Motor Brackets (2)—Heavy-duty 1×1-inch angle iron. See **Figure 4**.

Hardware (Nuts, bolts and spacers—all of which may vary):

(3) Engine-mount bolts, 3/8×16×2¹/₂ inches long

(3) Spacers, 3/4-inch-diameter, 1¹/₄-inches-long steel pipe couplings. These spacers place the engine pulley in the same plane as the alternator pulley. Buy longer couplings and/or shorten them as needed to accurately align the two pulleys.

(2) Alternator mounting bolts to fit your alternator.

*The regimen is described in "A New Chip for Charging Gelled-Electrolyte Batteries," by Warren Dion, N1BBH, in *QST*, Jun 1987, pp 26-29.